

 erylğit

www.eryigit.com.tr

 /eryigittibicihazlar

 /eryi itmedikal

 /eryigittibicihazlar



1 - Central Sterilization Unit



2 - Sterilization Devices



3 - Washers - Disinfector Drying Device



4 - Operation Tables



7 - Auxiliary Central Sterilization Units Equipment



8 - Stainless Steel Equipments

INDEX



1	Central Sterilization Unit	09 - 25
	I. Central Sterilization Unit	
	II. Sterilisation Cycle	
	III. Sterilisation Process	
	IV. Our Laboratory	
	V. Tracking and Documentation System of Central Sterilization Unit	
2	Sterilization Devices	26 - 41
	I. Steam Sterilizer	
	II. Sterilizer Model Features	
	III. Large Capacity Industrial Type Sterilizer for Pharmaceutical and Medicinal Applications	
	IV. Hydrogen Peroxide (H ₂ O ₂) Gas Plasma Sterilizers	
	V. Hydrogen Peroxide (H ₂ O ₂) Gas Plasma Sterilizers Model Features	
3	Washers - Disinfector Drying Device	42 - 51
	I. Washer - Disinfector Drying Devices	
	II. Washer - Disinfector Drying Devices Small	
	III. Washer - Disinfector Drying Devices Middle	
	IV. Washer - Disinfector Drying Devices Large	
	V. Washer - Disinfector Drying Devices Car and Additional Units	
4	Operation Tables	52- 73
	I. STR Series Operation Tables and Accessories	
	II. Pozitions of the STR operation Table	
	III. GOLDBERG New Generation Operation Table	
	IV. Pozitions of the Operation Table	
	V. Gynecological, Urological and Delivery Tables	
5	Ceiling Type LED Operation Lamps	74 - 77
	I. Goldberg Ceiling Type LED Operation Lamps	
	II. Examination Lamp	
6	Consumables	78 - 79
	I. Surgical Sutures	
	II. Strilization and Tyvek Bobin	
	III. Disinfectants and Washer-Disinfector Solutions	
	IV. Hydrogen Peroxide (H ₂ O ₂) Cartridges	
7	Auxiliary Central Sterilization Units Equipment	80 - 81
	I. Air and Water Gun	
	II. Ultrasonic Washer	
	III. Packing Solutions	
	IV. RO Water Purifying System	
8	Stainless Steel Equipments	82 - 91
9	Medical Waste Management Solutions	92 - 93





Vision

To make ERYİĞİT a globally leading medical device manufacturer and a recognized brand.

Mision

To contribute to customers, company staff, society and the environment by sincere honesty and institutional efficiency.



As a leading manufacturing company ERYIĞİT Medical Devices Co has been active in the healthcare sector since 1991.



Halit ERYIĞİT

Chairman of the Board of Directors

LATEST TECHNOLOGY



Environment and quality

Eryiğit has the target to produce high quality medical devices with a reasonable price by using advanced technologies since 1991. Within this framework and this sense of responsibility, our main goal is to prepare a clean environment to the next generations by taking necessary precautions to minimize waste while manufacturing our medical devices.

With this business perspective, Eryiğit is dedicated to produce high quality products. Hence, all the products are manufactured in compliance with ISO 9001, ISO 14001, ISO 13485 standards, EN 285, 97/23 / EEC Pressure Equipment Directive and 93/42/EEC Medical Device Directive to meet the high expectations of customers.

MADE IN TURKEY TO THE WORLD...



Our company performs its production compliance with ISO 9001, ISO 13485 and ISO 14001 quality management systems. Due to the Eryiğit's awareness towards protecting environment, our company finalised the necessary work to meet the relevant legal requirements of environmental management system and received its ISO 14001 certificate. Our company also holds CE1984 M.D.D (Medical Devices Directive) and CE1783 P.E.D (Pressure Equipment Directive) certificates.

Additionally our hard work has been yielded and we received our Type Test Certificate after passing the tests carried out by the German accredited institute HYGCEN GmbH. Validation tests accordance with TS EN 17665-1 have been carried out by HYGCEN for the steam sterilizers and we passed them successfully.

As one of the pioneer companies in national health sector, ERYIĞİT Medical Devices Co. carries out its production activities in its 10,000 square-meter factory located in Ankara Ostim Organized Industrial Zone.





We Are Exporting to
50 in the world
1500 Hospitals in
81 Cities in Turkey



“Produced in Turkey sold to world...”



www.eryigit.com.tr



1 - Central Sterilization Unit

- I. Central Sterilization Unit
- II. Sterilisation Cycle
- III. Sterilisation Process
- IV. Our Laboratory
- V. Tracking and Documentation System of Central Sterilization Unit





www.eryigit.com.tr



Eryigit
TIBBİ CİHAZLAR A.Ş.





I. Central Sterilization Unit

ERYİĞİT provides turn key services, including designing, installing and commissioning central sterilization units for hospitals ranging from small to large scale..







ERYİĞİT provides services for designing, installing and commissioning of central sterilization unit for:

- University hospitals,
- Training and research hospitals,
- Government hospitals
- Military hospitals,
- Private hospital and health institutions
- Veterinary sector and medicine sector

The major aim of ERYİĞİT is to manufacture medical devices and equipments according to our customers' needs and expectations.

ERYİĞİT has successfully completed many turn key projects for central sterilization units in the last twentythree years.

- Ankara Gülhane Military Medicine Academy (GATA),
- Gaziantep Dr. Ersin ARSLAN Government Hospital,
- Ordu Government Hospital,
- İstanbul Güngören Oral and Dental Health Care Center,
- Sungurlu Government Hospital,
- İstanbul Bayrampaşa Government Hospital
- Darıca Oral and Dental Health Care Center
- Sungurlu Government Hospital,
- İstanbul Bayrampaşa Government Hospital
- Darıca Oral and Dental Health Care Center

Our activities are as follows:

- Project planning and preparing scaled blue prints,
- Consulting customers for optimum solutions in terms of area allocation and installation of sterilization units,
- Choosing appropriate equipment and materials.
- Installing hygienic air-conditioning system and organizing the dirty-clean areas,
- Building Central Sterilization Units together with the water, electricity and drain system connections,
- Setting up units for collecting, separating, washing and decontaminating dirty materials.
- Building units for preparing, packing, and wrapping, materials to be sterilized.
- Building storage, distribution and quality control units for the materials to be sterilized.
- Providing services for installation, testing, validation, and commissioning of washing and disinfection equipment.

“WE ARE YOUR SOLUTION PARTNER IN THE AREA OF CENTRAL STERILIZATION AND OPERATING ROOM EQUIPMENT”





A place where clean and sterile materials are stored before delivery.

5 Delivery



II. STERILISATION CYCLE

The process where all micro organisms, spors on / in the eqipment are totally removed.

4 Sterilisation



1 Acceptance

Area where the non-steril equipments are accepted, categorized, cleaned and decontaminated.

Central Sterilization Unit

Central Sterilisation Unit: Sterilisation must not be accepted as a simple process. It must be evaluated like supplying materials for proper medical usage namely a manufacturing process. A sterilisation is a sequence of processes which includes the transfer of the equipments, cleaning and decontamination, carrying the equipments to preparation and maintenance area, counting, checking, packing, sterilising, storing and keeping them steril till to the area where it is going to be used.

2 Washing

Area where the equipments are washed roughly and put into washing-disinfection process.

Area where the equipments are sealed according to the sterilisation rules.

3 Packing

III. STERILISATION PROCESS



Decontamination:

A process which organic substances are removed from the surface with physical and/or chemical methods, before a sterilisation and disinfection processes, to make it safe for a person to touch the materials.



Disinfection:

It is process which substances or micro organisms (bacteria spors excluded) are cleaned or reproduction is stopped. Bacteria spors and micro bacterias are categorized in low, medium and high disindection according to their effecting levels.



Sterilisation:
It is a process which all micro organisms and spors are totally removed from surface or inside the materials.

Validation:
The proof, that sterilisation system and process are supplying the predefined condition continuously.





German accreditation company, "Hygcen GmbH" is the solution partner of Eryiğit in validation services worldwide.

ГОЩЕДЬКО



IV. Our Laboratory

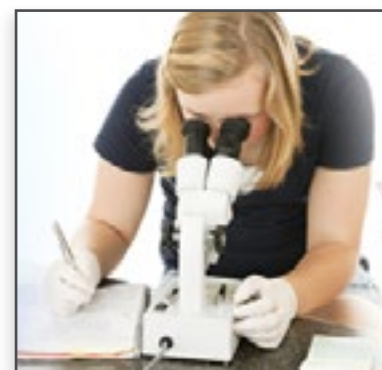

ALL OUR PRODUCT TESTS AND RD STUDIES ARE MADE
METICULOUSLY IN OUR LABORATORIES AND ANALYZED AFTERWARDS.

 Eryiğit





ERYİGİT serves about the design, installation and implementation of CSU turnkey projects for the hospitals whose bed capacities ranging between 30 – 1700.

V. Tracking and Documentation System of Central Sterilization Unit

With the Steril Net Barcode System;

- Each surgical instrument is QR coded and reliably tracked
- Coding system enables the hospital staff to prepare the surgical instruments with high precision
- An ID card is prepared for each instrument
- SterilNET software enables the hospital staff to use all the surgical instruments with a high degree of efficiency

If surgical instruments can be barcoded and inventorized with the help of SterilNET software system;

All stages of sterilization process can be monitored by means of coding system,

Computer Aided central sterilization unit and sterilization tracking/monitoring system are assumed to be the right choice for the total quality management,

SterilNET enables the hospital staff to follow up all sterilization process easily,

SterilNET is used to set up a detailed product database of other manufacturers,

When a surgical instrument is barcode marked, it is automatically included in the inventory. This allows hospital staff to control the inventory efficiently.

Why Steril Net?

- User friendly and easily adaptable,
- Helps to keep the regular inventory of instruments,
- Provides statistical information regarding surgical instruments,
- Reminds maintenance schedule,
- Provides package tracking,
- Tracks lost and damaged surgical instruments,
- Follows up consigned company sets,
- Provides customised reports,
- Barcodes the surgical instruments without causing any damage,
- Ensures the traceability of surgical instruments,
- Keeps the record of the usage frequency of the surgical instruments,
- Keeps the record of the sterilization frequency of the surgical instruments,
- Tracks the parts inventory of the equipments,
- Tracks the customizing of the surgical sets for doctors and medical departments,
- Tracks the packaged sets,
- Tracks the maintenance frequency of the surgical instruments,
- Keeps records and reports of the medical staff of the Central Sterilization Unit,
- Prepares reports of the sterilization units periodically on daily, monthly and yearly basis,



Sterilization Cycle

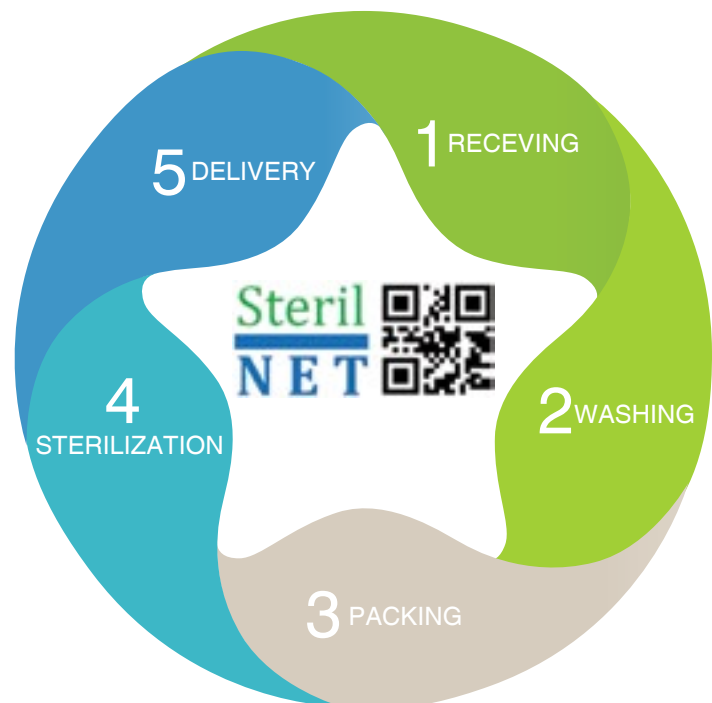

If you use the system;

- You should not worry about the programme, not meeting your needs,
- Because the system is very flexible and it can be integrated into your institutional organization,
- You can prepare the inventory of your surgical instruments and manage them easily,
- You can follow up all sterilization process easily,
- you can manage the sterilization unit within the frame of quality management system.



2 - Sterilization Devices

- I. Steam Sterilizer
- II. Sterilizer Model Features
- III. Large Capacity Industrial Type Sterilizer for Pharmaceutical and Medicinal Applications
- IV. Hydrogen Peroxide (H_2O_2) Gas Plasma Sterilizers
- V. Hydrogen Peroxide (H_2O_2) Gas Plasma Sterilizers Model Features



I. Steam Sterilizer

ERY T steam sterilizers are designed to sterilize;

- Textiles,
- Surgical and dressing instruments,
- Rubber and glass materials,
- Bottled liquids.



High Quality of Standarts

ERYİĞİT manufactures all sterilizers in accordance with very strict quality and safety standards such as Medical Device Directive (93/42/EEC), Pressure Equipment Directive (97/23/EEC), Standard (EN285), Steam Sterilizer Electromagnetic Compatibility (EMC) Directive and the Low Voltage Directive (LVD)



German accreditation company, "Hygcen GmbH" is the solution partner of Eryigit in validation services worldwide.

Reliable and Robust production

Exterior Body and Frame: The body and the framework are constructed of electrostatic powder painted structural steel and stainless steel with AISI 304 grade respectively. Despite the compact modular design, all components are mounted on this framework and are easily accessible for maintenance from either sides.

Sterilization Cell:

Constructed with a chamber and jacket, made of AISI 316L and AISI 316 Ti grade stainless steel with the thickness of 6 mm. and 2.5 mm, respectively.

Doors and panels:

Constructed with AISI 304 grade stainless steel, both single and double models with sliding types is available. All sterilizers are fitted with AISI 304 grade stainless steel panels. Special panel designs can be arranged upon request.

Piping System:

Pipes and fittings are made of stainless steel AISI 304 and MS 58 brass. Electrical and pneumatically operated valves are available.

Door Options

Steam Sterilizers can be manufactured with single or double doors (septic-aseptic) options.

The model with vertically sliding doors offered, fully automatic or manually operated.

All doors have the security system to prevent opening the doors or beginning the process.

- If one of the double doors left accidentally open,
- If one sterilization chamber is under pressure,
- If one temperature of the sterilization chamber exceeded the level of safety limits.
- If there is a difficulty or blockage to open and close the sliding door, the process is terminated automatically.

Hot and Clean Steam

All sterilizers are heated with wet and saturated steam. Steam can be supplied, either the hospital's central steam system or built-in electrical steam generator. Steam supply is controlled automatically. Purified and eminalized water should be used to provide clean steam.



“Control System is designed to allow easy usage and can be programmed via a keypad, displayed on the touch screen, that enables the user to select any programme needed”

STERILIZATION, SHOULDN'T BE ACCEPTED AS A SIMPLE PROCESS. IT MUST BE EVALUATED LIKE PROVIDING CONVENIENT MATERIALS FOR MEDICAL PURPOSES AND AS A PRODUCT PROCESS.



Autoclave device validation testing graphics

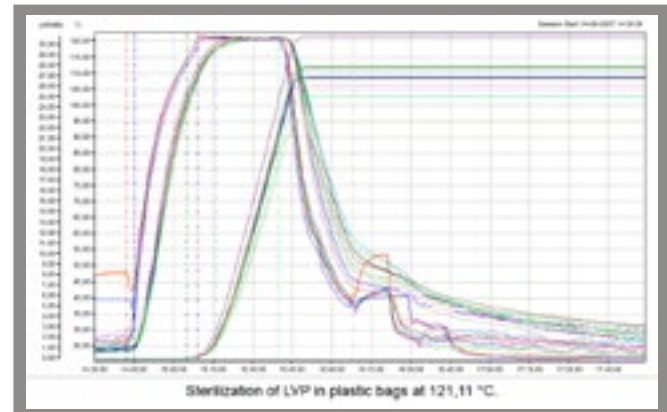
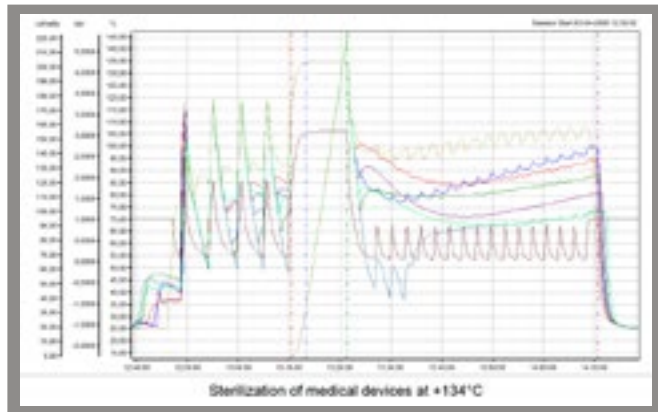





Laboratory Type Vertical Autoclave 75 liter model has two types as with vacuum and non-vacuum



II. Sterilizer Model Features

CHAMBER DIMENSIONS	MODELS	MODELS				DOOR DIMENSIONS			PACKING			VOLUME AND POWER				WEIGHTS		STU CAPACITY BY STEAM STERILIZER MODELS	
		DIA (mm)	HEIGHT (mm)	WIDTH (mm)	DEPTH (mm)	WIDTH (mm)	DEPTH (mm)	HEIGHT (mm)	WIDTH (mm)	DEPTH (mm)	HEIGHT (mm)	BOILER VOLUME (lt)	POWER GENERATOR (3 phase / 400 AC)	INSTALLED CAPACITY	GENERATOR CAPACITY	DEVICES (kg)	PACKAGING (kg)	DEVICE VOLUMES	STU CAPACITY
100 lt	STR 4407	-	400	400	650	810	1020	1650	826	1036	1066	100	20 kW	30 kW	60 lt	480	650	100 lt	1
160 lt	STR 4410	-	400	650	650	810	1020	1900	826	1036	1916	160	20 kW	30 kW	60 lt	610	780	160 lt	2
250 lt	STR 5510	-	500	500	1000	660	1370	2000	686	1386	2016	250	30 kW	40 kW	60 lt.	750	900	250 lt	-
300 lt	STR 5512	-	670	700	710	1080	1080	1950	1096	1096	1966	300	30 kW	40 kW	60 lt	890	1070	300 lt	4
422 lt	STR 6610	-	670	700	1000	1080	1370	1950	1096	1386	1966	422	40 kW	50 kW	70 lt	1050	1250	422 lt	6
550 lt	STR 6613	-	670	700	1300	1080	1670	1950	1096	1686	1966	550	40 kW	50 kW	70 lt	1110	1290	550 lt	8
750 lt	STR 7712	-	670	700	1600	1080	1970	1950	1096	1986	1966	750	50 kW	60 kW	70 lt	1310	1510	750 lt	10
900 lt	STR 7715	-	670	700	1950	1080	2320	1950	1096	2336	1966	900	60 kW	70 kW	70 lt	1520	1720	900 lt	12
1000 lt	STR 7717	-	750	750	1800	1290	2170	2040	1306	2186	2056	1000	60 kW	70 kW	70 lt	1520	1720	1000 lt	12
2000 lt	STR 2000	-	1230	1112	1450	2990	1840	2300	3006	1856	2316	2000	100 kW	120 kW	100 lt	2800	3200	2000 lt	-
75 lt	STR 75	400	-	-	600	880	605	1000	896	621	1016	75	7,5 kW	20 kW	16 lt	175	225	75 lt	-
75 lt	STR 75V	400	-	-	600	1055	620	1015	1071	636	1031	75	7,5 kW	20 kW	16 lt	175	240	75 lt	-

CHAMBER TEST RESULTS

Chamber Test Pressure	7 Bar
Chamber Test Temperature	150 °C
Chamber Operating Pressure	2.8 Bar
Chamber Operating Temperature	140 °C

Generator Test Pressure	7 bar
Generator Test Temperature	160 °C
Generator Operating Pressure	3 bar
Generator Operating Temperature	150 °C

“Steam Sterilizers, are equipped with an electronic pressure transducer to maintain the desired pressure values against the ambient pressure variations”



Autoclave Cars



Standart



Optional

III. Large Capacity Industrial Type Sterilizer for Pharmaceutical and Medicinal Applications

“High performance and technology to meet the customer demands”



“1000 lt, 2000 lt, 3000 lt and 5000 lt chamber capacity equipment options can be manufactured upon request”

CHAMBER DIMENSIONS

MODELS STR 2000	
Chamber Volume (lt)	2000
Diameter (mm)	-
Height (mm)	1112
Width (mm)	1230
Depth (mm)	1450

SINGLE SLIDING DOOR DIMENSIONS

MODELS STR 2000	
Height (mm)	2990
Width (mm)	2300
Depth (mm)	1840

DOUBLE SLIDING DOOR DIMENSIONS

MODELS STR 2000	
Height (mm)	3006
Width (mm)	2316
Depth (mm)	1856

VOLUME AND POWER

MODELS STR 2000	
Chamber Volume (lt)	2000
Generator Power (3 Phase / 400 ±10 V AC)	100
Total Power (kW)	120
Generator Volume	100

WEIGHTS

MODELS STR 2000	
Equipment (kg)	2800
Packing (kg)	3200

CHAMBER LOAD CAPACITY

MODELS STR 2000	
Chamber Capacity (lt)	2000
STU Capacity (lt)	24

IV. Hydrogen Peroxide (H₂O₂) Gas Plasma Sterilizers





- ▶ Sterilization process is initiated with pre vacuuming,
- ▶ Plasma is generated in the sterilization chamber,
- ▶ After the injection of H_2O_2 , plasma is created and the H_2O_2 vapor provides an effective sterilization in the chamber
- ▶ Above-mentioned stages are repeated as part of the cycle to obtain a sterilization with 10-6 SAL
- ▶ At the end of the cycle, H_2O_2 vapor turns into pure water and oxygen such that toxic residuals do not remain on the sterilized material.
- ▶ For the next sterilization cycle, the chamber is flushed with dry air.





German accreditation company, "Hyggen GmbH" is the solution partner of Eryigit in validation services worldwide.



V. Hydrogen Peroxide (H₂O₂) Gas Plasma Steriliziers Model Features

TECHNICAL SPECIFICATIONS

DIMENSIONS	TSP 80	TSP 120	TSP 135	TSP 160	TSP 200
DIMENSIONS					
WIDTH (mm)	535	800	735	800	1000
HEIGHT (mm)	1170	1750	1775	1750	2190
DEPTH (mm)	890	1330	995	1530	1910
WEIGHT (mm)	330	350	380	400	440
PRISMATIC CHAMBER DEVICE					
WIDTH (mm)	400	400	453	450	450
HEIGHT (mm)	400	400	400	450	450
DEPTH (mm)	500	750	700	790	987
EFFECTIVE VOLUME (Lt)	80	120	135	160	200
CYLINDRICAL CHAMBER DIMENSIONS					
DIAMETER Ø (mm)	400	400	400	450	450
DEPTH (mm)	636	955	1073	1000	1250
EFFECTIVE USEABLE VOLUME (Lt)	80	120	135	160	200

STANDART PROGRAMS

Program 1 (Short Program)	Surface sterilization
Program 2 (Standart Program)	Sterilization for cavities and short and thick lumens
Program 3 (Advanced Program)	Sterilization for long and narrow lumens and adherent surfaces

Hydrogen Peroxide (H₂O₂) Gas Cartridges



Touch screen; simple and easy to use; single or double door options

Preparing the heat and moisture-sensitive instruments to be used under dry conditions. Prevents the corrosion caused by moisture, extending life span of the instruments. Reduced the maintenance cost.

GOLDBERG series plasma sterilization system can be monitored remotely with the help of independent monitoring system to review the cycle parameters. The system is an ideal alternative for rapid and safe sterilization for the instruments requiring low-temperature sterilization.

Cylindrical or prismatic sterilization chamber provides a large volume with short (45 minutes) and long (70 minutes) cycle options that enable the user to operate the system fast and effectively. Sterilized instruments are dried and packed with 10-6 Sterility Assurance Level (SAL).

Electrical wiring is sufficient to install the GOLDBERG Series devices. Water connection, ventilation, (and subsequent substructure) are not required. Only one square-meter area is sufficient for installation and the device can be moved with the help of its castor system.

System works with (non-toxic) hydrogen peroxide solution cassette and at the end of the sterilization process hydrogen peroxide is converted into oxygen and water vapor. It is absolutely safe for the health care staff, patients, and environment.

Device is used for metal or nonmetal medical and electronic materials excluding the ones not resistant to humidity and high temperature such as copper and cellulose based materials.

Door sealing is provided by an o-ring.

The sterilization process is controlled by a microprocessor.

Built-in printer is available.

Display shows all cycles and maintenance time.

Audible and/or visual alarms with print-out are issued to signal machine faults/malfunctions.

Emergency system prevents the opening of the doors until the cycle is over.

Pressure is controlled electronically by means of a builtin pressure transducer.

Intake air is cleaned via a HEPA filter.

The injected amount of hydrogen peroxide is constant, being independent of the volume and quantity of the materials to be sterilized.

Operation Voltage/ Frequency: 220-380 V / 50 Hz.



3 - WASHER - DISINFECTOR DRYING DEVICE

- I. Washer - Disinfector Drying Devices
- II. Washer - Disinfector Drying Devices Small
- III. Washer - Disinfector Drying Devices Middle
- IV. Washer - Disinfector Drying Devices Large
- V. Washer - Disinfector Drying Devices
Car and Additional Units



I. Washer - Disinfector Drying Devices

Washer disinfectors are designed to be utilized in operating theaters and anesthesia units where the performance expectations (i.e. capacity, volume, operational flexibility) are significantly high.

It provides ultimate solution for high quality washing, disinfection and drying of surgical materials, hoses, bottles and glass materials etc.

Washer disinfector ensures that all material will be cleaned thoroughly and homogeneously.

Ergonomic design and display with clear-cut instructions provide washer disinfector uninterrupted operation.

Easy to use device, with operating parameters monitored and recorded via an externally connected.

General Specifications;

- The 5-level apparatus offers a large washing capacity for general purpose materials.
- With an additional apparatus for cannular and indented structures; the 4 - level apparatus accommodates a washing capacity for approximately 300 pieces of general-purpose materials.
- The 3-level apparatus allows cleaning of anesthesia accessories.
- Washing apparatus can accommodate a maximum of 4 large material containers.
- The 4 - level washing apparatus comes with an accessory to wash surgical trays and general purpose materials.
- The 4 - level apparatus can wash 72 cannular or indented structures along with 300 pieces general purpose materials.



Our washing and disinfection device
TUBITAK R & D Project No. 3120720
It developed within the scope.

II. Washer - Disinfector Drying Devices Small

Model: GOLDBERG GY150
Small Capacity Washer Disinfectors-
Under counter 150 L Capacity

STANDART FEATURES

- 10+20 programs and touchscreen
- Washing chamber 150 L, 8 DIN 1/1 baskets
- Chamber dimensions (WxHxD): mm 540 x 510 x 550
- Device dimensions (WxHxD): mm 900 x 840 x 630
- Horizontal opening stainless steel door
- Standard Power: 230 V / 1L + N + PE / 50 Hz
- Electrical Power: 4,5 kW
- Cabinet for storing chemical bottles
- 2 + 2 (optional) flowmeters and dosing pump for chemicals with liquid level sensor
- Washing Pump: 400 L / min
- Pump pressure control
- Washing chamber heaters: 3 kW
- Electrical drying: 200 m³ /h (without resisting pressure)
- Drying heaters: 2 kW
- Pre filter F-Class
- Hepa filter H14
- Control sensor for HEPA drying filter
- Port for external temperature sensor
- Automatic recognition sensor for loading carts
- RS 232 connection port
- Internal steam condenser (optional)
- Internal water softener (optional)
- Internal printer (optional)



III. Washer - Disinfector Drying Devices Middle

Model: GOLDBERG GY225
 Small Capacity Washer Disinfectors -
 Manual Door 225 L Capacity

STANDART

- 10+40 programs and touchscreen
- Washing chamber 225 L, 8 DIN 1/1 baskets
- Chamber dimensions (WxHxD): mm 560 x 600 x 620
- Device dimensions (WxHxD): mm 675 x 1850 x 700
- Horizontal opening, heat proof, tempered glass door(s) with stainless steel frame
- Standard Power: 400 V / 3L + N + PE / 50 Hz
- Electrical Power: 12 kW / 20 A
- 2 + 2 (optional) flowmeters and dosing pump for chemicals with liquid level sensor
- Washing Pump: 600 L / min
- Pump pressure control
- Washing chamber heaters: 10 kW
- Electrical drying: 200 m3 /h (without resisting pressure)
- Drying heaters: 10 kW
- Pre filter F-Class
- Hepa filter H14
- Control sensor for HEPA drying filter
- Port for external temperature sensor
- Valve for water sampling
- Automatic recognition sensor for loading carts
- Chamber lightening
- RS 232 connection / ethernet connection port
- Internal steam condenser (optional)
- Internal water softener (optional)
- Internal printer (optional)



IV. Washer - Disinfector Drying Devices Large

Model:GOLDBERG GY290

Medium Capacity Washer Disinfectors -

Manual Door- Automatic Door 290 L Capacity

STANDART FEATURES

- 10+90 programs and touchscreen
- Washing chamber 290 L, 10 DIN 1/1 baskets
- Chamber dimensions (WxHxD): mm 620 x 670 x 670
- Device dimensions (WxHxD): mm 816 x 2150 x 900
- Horizontal opening, heat proof, tempered glass door(s)
- with stainless steel frame - manual door
- Vertical opening, heat proof, tempered glass door(s) with stainless steel frame – automatic door
- Standard Power: 400 V / 3L + N + PE / 50 Hz
- Electrical Power: 12 kW / 20 A
- 2 + 2 (optional) flowmeters and dosing pump for chemicals with liquid level sensor
- Washing Pump: 700 L / min
- Pump pressure control
- Washing chamber heaters: 10 kW
- Electrical drying: 400 m³ /h (without resisting pressure)
- Drying heaters: 10 kW
- Pre filter F-Class
- Hepa filter H14
- Control sensor for HEPA drying filter
- Port for external temperature sensor
- Valve for water sampling
- Automatic recognition sensor for loading carts
- Chamber lightening
- RS 232 connection / ethernet connection port
- Internal steam condenser (optional)
- Internal water softener (optional)
- Internal printer (optional)



IV. Washer - Disinfector Drying Devices Large

Model: GOLDBERG GY 360

Large Capacity Washer-Disinfectors

360 L Capacity

STANDART FEATURES

- 10+90 programs and touchscreen
- Washing chamber 360 L, 15 DIN 1/1 baskets
- Chamber dimensions (WxHxD): mm 660 x 720 x 750
- Device dimensions (WxHxD): mm 1000 x 2150 x 950
- Vertical opening, heat proof, tempered glass door(s)
- Standard Power: 400 V / 3L + N + PE / 50 Hz
- Electrical Power: 12 kW / 20 A
- 2 + 2 (optional) flowmeters and dosing pump for chemicals with liquid level sensor
- Washing Pump: 800 L / min
- Pump pressure control
- Washing chamber heaters: 10 kW
- Electrical drying: 400 m³ /h (without resisting pressure)
- Drying heaters: 7,5 kW
- Pre filter F-Class
- Hepa filter H14
- Control sensor for HEPA drying filter
- Port for external temperature sensor
- Valve for water sampling
- Automatic recognition sensor for loading carts
- Chamber lightening
- RS 232 connection / ethernet connection port
- Internal steam condenser (optional)
- Internal water softener (optional)
- Internal printer (optional)



V. Washer - Disinfector Drying Devices Car and Additional Units



STANDART



German accreditation company, "Hygcen GmbH" is the solution partner of Eryigit in validation services worldwide.





OPTIONAL



OPTIONAL

For other accessories, get in contact with our company !



4 - Operation Tables

- I. STR Series Operation Tables and Accessories
- II. Positions of the STR operation Table
- III. GOLDBERG New Generation Operation Table
- IV. Positions of the Operation Table
- V. Gynecological, Urological and Delivery Tables



 eryiğit

“ERYİĞİT operating tables; are designed for general surgery, Urological, Gynecological, Orthopedical, Ophthalmological, Neurosurgical, ENT (Ear,nose and throat), cardiological operations”

I. STR Series Operation Tables and Accessories

ERYİĞİT operating tables; are designed for General Surgery, Urological, Gynecological, Orthopedical, Ophthalmological, Neurosurgical, ENT (Ear,nose and throat), cardiological operations.

Table top tray, the head, the two-piece back, hip and leg portion including a two-part consists of six chapters. The table, up and down, the back part of Trendelenburg, reverse Trendelenburg, right - left hand control with the help of the lateral movements of the moving wire electro - hydraulic system.

Manually moving the head and foot part of the request may be extended up to 5 cm table height. Can be remove if you want.

Operating table (General purpose)

2 piece foot section can be moved 90 degrees down,180 degree left and right, 30 degree up. The base platform and body are covered with stainless steel telescopic panels which are protected against liquidindifusion from outside.These panels are removable. Table top is covered with antistatic and antibacterial cushions with the thickness of 5 cm or a 2- layer viscoelastic polyurethane cushion with the thickness of 8 cm. These pads are removable and easily cleanable. The table is suitable for placing C arm X-ray device and table top is X-ray permeable. Film cassettes in several sizes can be placed from head and foot sections for various patient positions.

Accessories can be placed easily with the help of a stainless steel rail system which allows the user to add any accessories without removing the others. The rail system are fixed on the both sides of the table longitudinally.

The base of the table is designed in the form of a T-shape to help the surgon to get closer to the patient as much as possible. The table has four independent swivel castors. There is a brake controlled by a foot pedal or an electro-hydraulic system. Carrying capacity of the table is 350 kg, also it should not vibrate or wobble while providing a stable and well-balanced operation. The table is protected against electro static discharges by insulation and grounding the chassis to ensure the safety of the patient as well as the doctor.



Optional Features:

- Interchangeable head and leg sections.
- In order to increase the active area of the C-arm scopyy ,single piece leg section can be attached to head and vice versa.
- Sliding back and forth movements ranges 30 cm. (Standard feature of model STR 2000F)
- 12 cm height adjustable manual or electro-hydraulic kidney elevator system.
- Electro-hydraulic brake system.
- Table can rotate 360 degrees on its axes.
- Special clamping system is available to hold accessories in place on the rails
- Visco-elastic cushion.
- Two-piece back rest.
- Safety system on the hand-held control unit to prevent misuse.

Accessories

Standart Accessories

STR 127: Polyurethane Cushion Set	1 Piece	STR 107 : Body straps	1 Piece
STR 105: Arm support	2 Piece	STR 101 : IV pole	1 Piece
STR 104: Shoulder support	2 Piece	STR 102 : Anesthesia Frame	1 Piece
STR 108: Knee crutches	2 Piece	STR 103 : Waste bowl	1 Piece
STR 106: Body supports	2 Piece	STR 129 : Hand control	1 Piece
STR 120 Arm straps	2 Piece	STR 109 : Accessory clamp	8 Piece
STR 110: Accessory clamp	2 Piece	STR 121 : Leg straps	2 Piece

Optional Accessories

STR 118: One piece leg section	STR 112: Orthopedic traction system
STR 111: Spiked head caption connection for sitting position	STR 113: Wrist belt
STR 119: Rail System for Accessories	STR 124: Accessory table
STR 117: Proctology Support	STR 126: Visco - elastic cushion set
STR 114: "U" Type head support	STR 114: X-Ray cassette holder
STR 115: Kidney elevator	STR 122: Silicon head support
STR 123: Silicon body support	STR 128: Radiographic bench top set
STR 125: Shoulder Arthroscopy Set	

Technical Features

Carrying Capacity	350 kg
Net Weight	270 kg
Gross Weight	350 kg
Package Dimensions	700x900x1200 mm (wxhxd)
Supply Voltage	230 V/50-60 Hz
Battery Capacity	12 A/h
Battery Charge Voltage	30 VDC
Battery Type	Dry and maintenance free

STR 2000F model has the following additional technical features when it is compared with model STR 2000:

- Battery durability 30-60 minutes (200 Movements)
- Secondary control panel on the body.
- 30 cm. of sliding back and forth movements



II. POSITIONS OF THE STR OPERATION TABLE

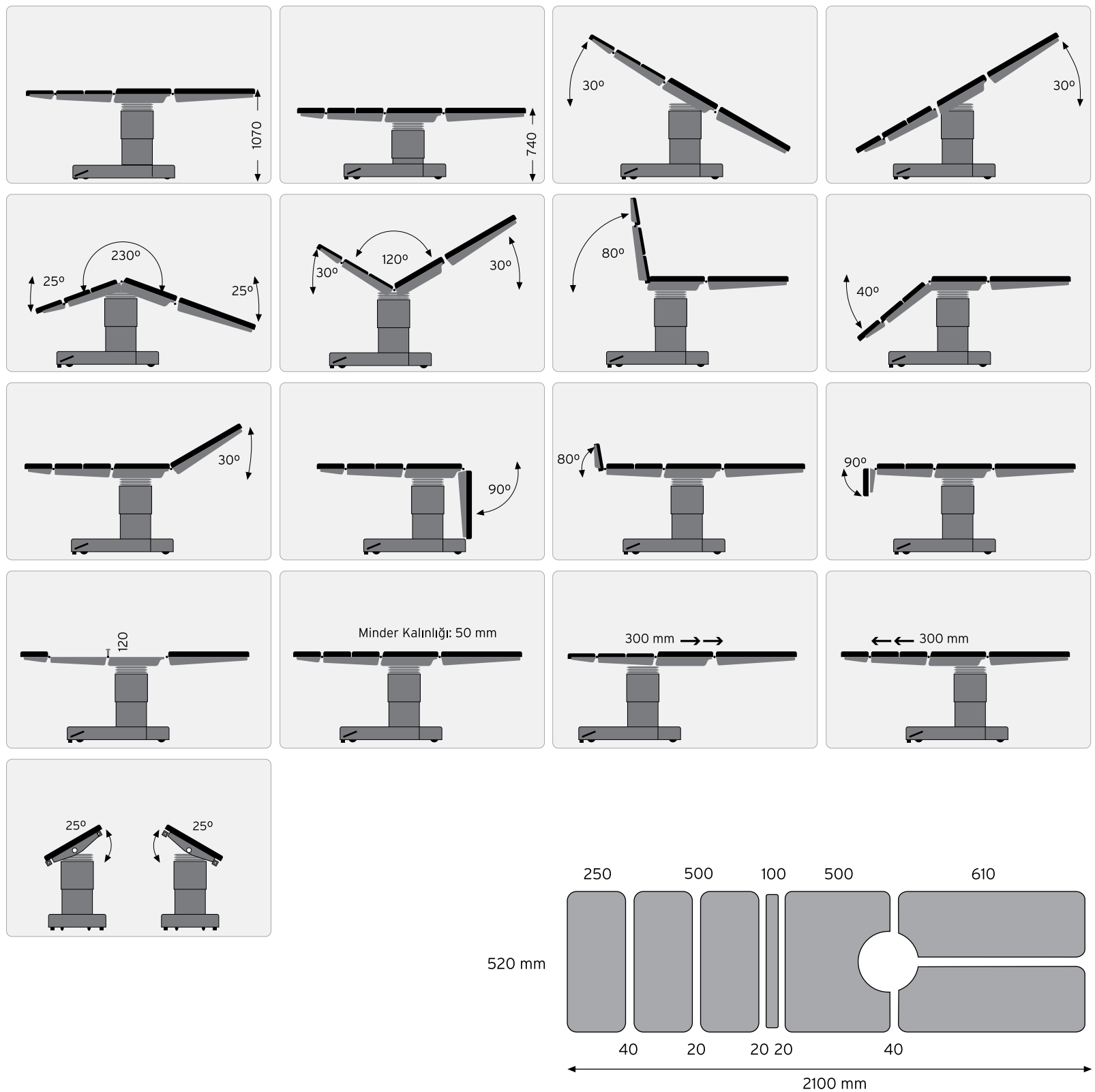

ERYIĞIT Operating Tables are designed to use in General Surgery, Urological, Gynecological, Orthopedical, Ophthalmological, Neurosurgical, ENT (Ear,nose and throat), cardiological operations.

eryiğit



GOLDBERG®





MAXIMUM CAPACITY

500 kg

400 kg

300 kg

200 kg

100 kg

III. GOLDBERG New Generation Operation Table

- **GOLDBERG** Operating Tables are designed to use in general surgery, Urological, Gynecological, Orthopedical, Ophthalmological, Neurosurgical, ENT (Ear, nose and throat), cardiological operations.
- In addition to the Standard Features:
- Zero Positioning (except head and foot sections)
- Saving up to four frequently used positions
- Fixing the table to floor with four electrohydraulic pistons guided by hand-held or auxillary control panel. Besides manual brakes unloading feature.
- Prevent the movements without fixing the pistons to the floor.
- Unlocking the brake-system manually.
- Single button command of flex and reflex movements on the hand-held control.
- Display of table positioning on the LCD screen of hand-held control.
- Back lighting of positioning buttons of hand-held control.
- Interchangeable head and foot sections.
- Height adjustment from 550 mm to 1025mm (without cushion) to allowing surgeon to operate while sitting.
- Safety lock on the hand-held control. (Optional)
- Stand-by feature while the table is not in use and overlap and collision sensor feature. (Optional)
- **GOLDBERG** Operating Tables up to 45 cm horizontal sliding feature. (Optional)
- **GOLDBERG** Operating Tables leg parts can be moved electrohydroaulically 110 degrees down - 80 degrees up by means of hand remote and column control panel . (Optional)





“ High Mobility ”



GOLD



BERG®

“latest technology”



“Feature of lowering up to 55 cm”

IV. GOLDBERG POSITIONS OF THE OPERATION TABLE



N.N.T. SURGERY



BEACH - CHAIR POSITION



THORACIC, KIDNEY AND GALL BLADDER SURGERY



BEACH - CHAIR POSITION



SIPNAL INTERVENTION IN PRONE POSITION



SIDE POSITION FOR NEPHRECTOMY

GOLDBERG New Generation Operating Table Accessories



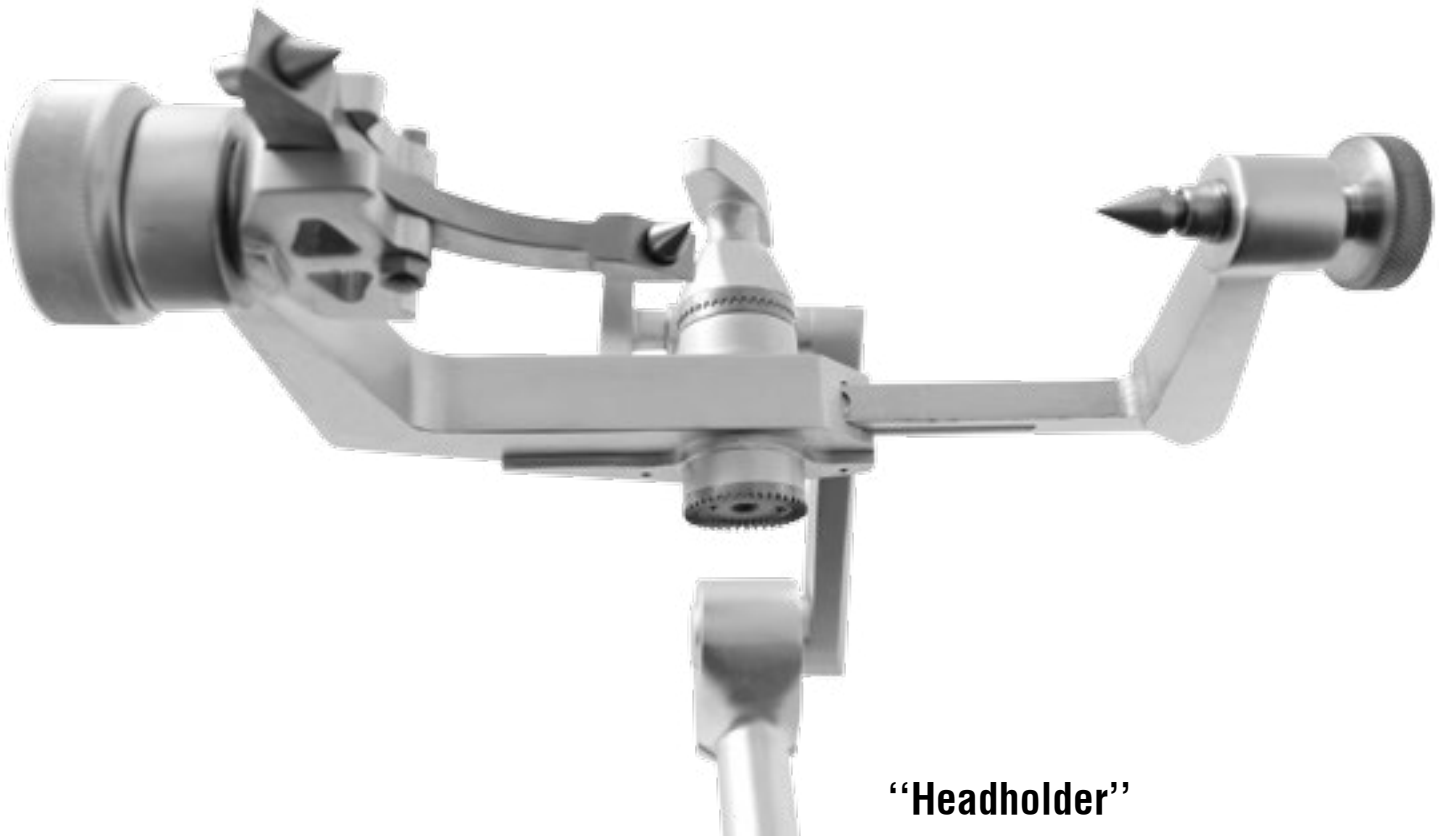

“Headholder”



Accessories Standart Accessories

GOLDBERG 127: Polyurethane Cushion Set	1 Set	GOLDBERG 107: Body straps	1 Piece
GOLDBERG 105: Arm support	2 Piece	GOLDBERG 101: IV pole	1 Piece
GOLDBERG 104: Shoulder support	2 Piece	GOLDBERG 102: Anesthesia Frame	1 Piece
GOLDBERG 108: Knee crutches	2 Piece	GOLDBERG 103: Waste bowl	1 Piece
GOLDBERG 106: Body supports	2 Piece	GOLDBERG 129: Hand control	1 Piece
GOLDBERG 120 Arm straps	2 Piece	GOLDBERG 109: Accessory clamp	8 Piece
GOLDBERG 110: Accessory clamp	2 Piece	GOLDBERG 121: Leg straps	2 Piece

Optional Accessories

GOLDBERG 118: One piece leg section	GOLDBERG 112: Orthopedic traction system
GOLDBERG 111: Spiked head caption connection for sitting position	GOLDBERG 113: Wrist belt
GOLDBERG 119: Rail System for Accessories	GOLDBERG 124: Accessory table
GOLDBERG 117: Proctology Support	GOLDBERG 126: Visco - elastic cushion set
GOLDBERG 114: “U” Type head support	GOLDBERG 114: X-Ray cassette holder
GOLDBERG 115: Kidney elevator	GOLDBERG 122: Silicon head support
GOLDBERG 123: Silicon body support	GOLDBERG 128: Radiographic bench top set
GOLDBERG 125: Shoulder Arthroscopy Set	



TRACTION SET





V. Gynecological, Urological and Delivery Tables

ERYİĞİT gynecological and urological tables are designed for gynecological and urological examinations and interventions. Wide range of application areas are offered by their ergonomic structure and various types of accessories.

ERYİĞİT gynecological and urological tables are designed for gynecological and urological examinations and interventions. Wide range of application areas are offered by their ergonomic structure and various types of accessories.

- Ergonomic structure and easy to use.
- Ergonomic cushions covered with waterproof material.
- Fireproof and antibacterial leather cover.
- Electro mechanic motor system, moving without noise and vibration, suitable for various patient positions.
- Arbitrary position options.
- Mobile foot pedal for controlling the table movements.
- AISI 304 quality stainless steel structure and bottom platform protected against liquid leakage from outside.
- Wheel system providing table to move to the required place.
- Brake system for fixing the table.

also it should not vibrate or wobble while providing a stable and well-balanced operation. The table is protected against electro static discharges by insulation and grounding the chassis to ensure the safety of the patient as well as the doctor.

Accessories

Standart Accessories			
Knee support (polyurethane)	2 Piece	Waste bowl	1 Adet
Arm support (polyurethane)	2 Piece	IV Stand	1 Adet
Holding handle (polyurethane)	2 Piece	Leg section	1 Adet

Gynecological, Urological and Delivery Tables

Height adjustment is made by a quite and non-vibrating electric motor controlled by pedal or hand command unit.

Back section movement is manually controlled by a gas piston to fix the position

General Features

- Carrying capacity of 200 kgs.
- Ergonomic structure and easy to use.
- Ergonomic cushions covered with waterproof material.
- Fireproof and antibacterial leather cover.
- Electro mechanic motor system, moving without noise and vibration, suitable for various patient positions.
- Arbitrary position options.
- Mobile foot pedal for controlling the table movements.
- AISI 304 quality stainless steel structure and bottom platform protected against liquid leakage from outside.
- Wheel system providing table to move to the required place.
- Brake system for fixing the table.

Optional Accessories

- Anesthesia frame
- Battery System
- Step

Model STR-200D

Height and back part movements of the table are made by three electro-hydraulic motors controlled via a pedal or hand command. It is designed to maximize the performance of the operator during the delivery procedure. Height can be adjusted between 560 mm and 900 mm which enables the patient to sit without using step.

TECHNICAL FEATURES

Operating Voltage	220-240 V AC / 50-60 Hz
Motor Power	0.4 kW
Carrying Capacity	200 kg

Model STR-201

Height adjustment is made by a electric motor controlled via a pedal or hand command. Back section movement is controlled manually by a gas piston to fix the position.

TECHNICAL FEATURES

Operating Voltage	220-240 V AC / 50-60 Hz
Motor Power	0.4 kW
Carrying Capacity	200 kg

Model STR-202

Height and sitting part movements are made by a electric motor controlled via a pedal or hand command . Back section movement is controlled manually by a gas piston to fix the position.

TECHNICAL FEATURES

Operating Voltage	220-240 V AC / 50-60 Hz
Motor Power	0.4 kW
Carrying Capacity	200 kg

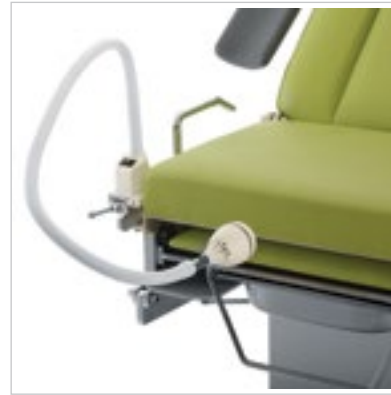

ERM- 201 ERM- 202 ERM- 203 ERM- 204

Max. 920 mm Max. 920 mm Max. 920 mm Max. 920 mm
Min. 670 mm Min. 670 mm Min. 670 mm Min. 670 mm

UP- DOWN MOVEMENT

Back Rest: 0 -75° Back Rest: 0 -75° Back Rest: 0 -75° Back Rest: 0 -75°
Food: 0-90° Food: 0-90° Food: 0-90° Food: 0-90°

BACKREST AND FOOT SUPPORT

Trendelenburg Trendelenburg
-5 / 300 -5 / 300

TRENDELENBURG

Stittin Stittin
-5 / 300 -5 / 300

SITTING PART

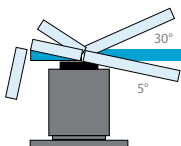
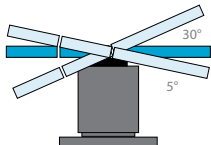
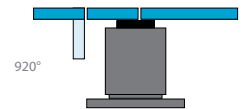
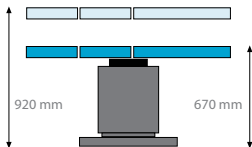

Model STR-203

Height and the back part movements are made by two electric motors controlled via a pedal or hand command.

Model STR-203T

Height and the back part movements are made by two electric motors controlled via a pedal or hand command.

Foldable foot and heel part can be positioned under the sitting part by means of the rail system which provides practical and easy use.

Model STR-204

Height and the back part movements are made by three electric motors controlled via a pedal or hand command.

TECHNICAL SPECIFICATIONS

Operating Voltage	220-240 V AC / 50-60 Hz
Motor Power	0.4 kW
Carrying Capacity	200 kg

TECHNICAL SPECIFICATIONS

Operating Voltage	220-240 V AC / 50-60 Hz
Motor Power	0.4 kW
Carrying Capacity	200 kg

TECHNICAL SPECIFICATIONS

Operating Voltage	220-240 V AC / 50-60 Hz
Motor Power	0.4 kW
Carrying Capacity	200 kg



ERG

5 - Ceiling Type LED Operation Lamps

- I. Ceiling Type LED Operation Lamps
- II. Examination Lamp

I. GOLDBERG Ceiling Type LED Operation Lamps

TECHNICAL FEATURE

TECHNICAL FEATURE			
General data	Designation/name	GOLDBERG LED 500	GOLDBERG LED 700
	Weight of the light head [kg]	15	18
	Service life [h]	>50000	>50000
Electrical Data	IP protection class	42	42
	Connected loads		
	Voltage [V]	24	24
	Voltage range [V]	20 to 32	20 to 32
	Power consumption, maximum [A]	2,0	2,5
	Power consumption, average [A]	1,6	2,1
	Photometric values	Rated power output [W]	40
Illuminance EC at distance of 1 m [klx]		130	160
Electronic brightness adjustment [klx]		40 to 130	40 to 160
d10 light field, \bar{E} at 10 % of the max. illuminance at a distance of 1 m [mm]		170 to 280	170 to 300
Field adjustment		yes	yes
Residual illuminance with shadowing by one mask, relative to EC [%]		55	65
Residual illuminance with shadowing by two masks, relative to EC [%]		45	55
Residual illuminance in standardized tube, relative to EC [%]		100	100
Colour rendering index Ra		96	96
Red rendering index		96	96
Illumination depth (L1/L2) 20% [mm]		1000	900
Illumination depth (L1/L2) 60% [mm]		550	510
Total irradiance at 130/160 klx [W/m ²]		480	520
Colour temperature [K]		4900	4900
Operating conditions		Irradiation/illuminance [lm/W]	290
	Temperature [°C]	5-40	5-40
	Relative Humidity [%]	95	95

LED Technology which is recently developed provides low energy consumption. Goldberg Serie developed with new standards is the newest generation of white light. LED Light with high light illumination quality, efficiency, natural light color, competitive price, cost effective maintenance and being less harmful to environment is the best choice for operating rooms.

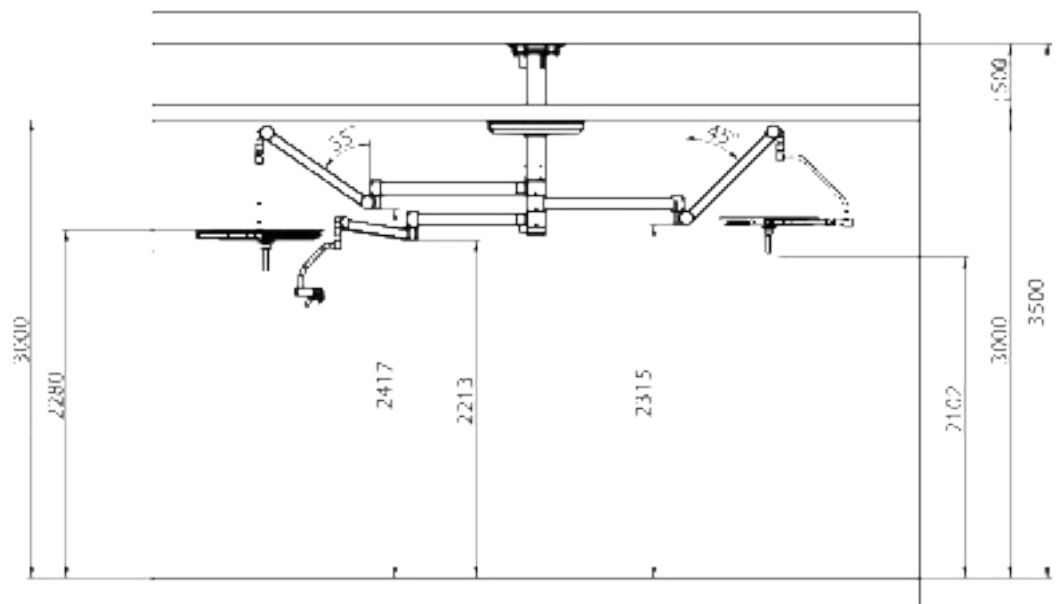



GOLDBERG®

II. Examination Lamp

Examination Lamp / MODEL ERML - 200

Used in gynaecological examination.

- LED light source providing cold light.
- Spiral systems allowing the operator, more comfortable working conditions.
- Easy mounting and demounting to the side rails of table.

Examination Lamp / MODEL ERML - 210

Used in gynaecological examination.

- Halogen light source providing cold light.
- Spiral systems allowing the operator, more comfortable working conditions.
- Easy mounting and demounting to the side rails of table.





6 -Consumables

- I. Surgical Sutures
- II. Strilization and Tyvek Bobin
- III. Disinfectants and Washer-Disinfector Solutions
- IV. Hydrogen Peroxide (H₂O₂) Cartridges

I. Surgical Sutures

Absorbable Surgical Suture	Performance and Undesirable Effects of Product: PGLA (Poly Lactic-co-Glycolic Acid) causes minimally initial inflammatory reaction in tissue and endogeneity of fibrous connective tissue. Absorbable surgical sutures should not be used where long term approximation of tissue under stress is needed. The skin sutures that need to remain for longer than 7 days may cause local irritation, so they should be removed if necessary. Also, absorbable suture causes temporary local irritation on the wounds, temporary foreign body inflammatory response and redness during absorption of subcuticular suture. PGLA / PGAR (Poly Lactic-co-Glycolic Acid) as all foreign bodies can increase the existing infection.		
The braided character of the product: Braided	Purpose: Using for general soft tissue closure procedure.		
			
Code Gauge:	0 1 3-0 4-0	Usage: The absorption of surgical suture by the body starts within 14 days after implantation, mass reduction of tensile strength of PGLA decreases up to 75% by the end.50% of original tensile strength remains within 3 weeks. All the absorption takes place within 56-70 days.	
PGLA [Poly Lactic-co-Glycolic Acid]	Place of Use in the Body	Intended Use in the Body	Duration of Stay in the Body
	<ul style="list-style-type: none"> Subcutaneous, General Surgery, Eye Surgery, Gynecology, Urology, Gastrointestinal Surgery, 	<ul style="list-style-type: none"> Excellent knot security, Minimal tissue reaction, smooth transition throughout tissue, General soft tissue approximation, intracutan, Ligation, 	14 days

Çeşit	USP No	Cm	İğne boyu	Circle
PGLA	1	90 cm	40 mm	1/2
PGLA	1	75 cm	40 mm	1/2
PGLA	0	75 cm	40 mm	1/2
PGLA	3/0	75 cm	30 mm	1/2
PGLA	4/0	75 cm	20 mm	1/2

II. Strilization and Tyvek Bobin



III. Disinfectants and Washer-Disinfector Solutions



IV. Hydrogen Peroxide (H₂O₂) Cartridges





7 - Auxiliary Central Sterilization Units Equipment

- I. Air and Water Gun
- I. Ultrasonic Washer
- III. Packing Solutions
- IV. RO Water Purifying System

Auxiliary Central Sterilization Units Equipment



I. Air and Water Gun:

- cleaning and disinfecting instruments with recessed surfaces,
- pressurized air or water connections,
- eight different adapters,
- pressure-resistant hose,
- wall mounted with holders for adapters.
- you can follow up all sterilization process easily,
- you can manage the sterilization unit within the frame of quality management system.



II. Ultrasonic Washer:

Basit ve anlaşılır kontrol paneli mevcuttur.

- Easy and comprehensible control panel,
- High operation frequency,
- Low noise,
- High-power ultrasonic generators,
- Chamber volume varies from 1.8 - 90 liters,
- Microprocessor controlled, temperature and cleaning duration.



III. Packing Solutions:

Wide range of products from the models suitable for small capacity clinics to the ones which are microprocessor controlled, for high-capacity hospitals.



IV. RO Water Purifying System:

Eryiğit Medical Devices Inc. offers reverse osmosis water purifying system consisting of water pump with stainless steel frame and water tank.



8 - Stainless Steel Equipments



 eryiğit

Stainless Steel Equipments



Tools & Medicine Cabinet
Model ER-1001 / ER-1002

- Designed for surgical operation and medical intervention rooms,
- Made of AISI 304 quality 18/8 CrNi stainless steel,
- Contains glass door with locker at the upper part, two drawers and one locker cupboard at the bottom,
- Removable drawers with telescopic rails for easy cleaning,
- Optional "suspension legs" replacing swivels for stationary version.
- Custom production for specific size.



Operation Room Glass Door Cabinet
Model ER-1001/ER-1002

- Designed for surgical operation and medical intervention rooms,
- Made of AISI 304 quality 18/8 CrNi stainless steel,
- Contains four stowing space separated by three shelves,
- Locking doors,
- Transparent glass doors
- Door handles and feet made of first class stainless steel,
- Suspension legs made of high quality stainless steel with adjustable height and balance,
- Custom production for specific size.



Dressing Trolley
Model ER-1051 / ER-1053

- Designed for medical dressing procedures,
- Made of AISI 304 quality 18/8 CrNi stainless steel,
- Serum bottle holder on table top,
- Contains five drawers,
- Removable drawers with telescopic rails for easy cleaning,
- Removable 12 lt waste bin,
- Bowl can be inserted under table when not used, enabling a smaller volume for trolley,
- Four swivel casters, two of them with brakes,
- Custom production for specific sizes.

Dressing Trolley with Drawers

Model ER-1054 / ER-1055

- Designed for medical dressing procedures,
- Made of AISI 304 quality 18/8 CrNi stainless steel,
- Serum bottle holder on table top,
- Contains three drawers and two cupboards,
- Removable drawers with telescopic rails for easy cleaning,
- Removable 12 lt waste bin,
- Bowl can be inserted under table when not used, enabling a smaller volume for trolley,
- Four swivel casters, two of them with brakes,
- Custom production for specific sizes.



Dressing Trolley

Model ER-1051 / ER-1053

- Designed for medical dressing procedures,
- Made of AISI 304 quality 18/8 CrNi stainless steel,
- Serum bottle holder on table top,
- Contains five drawers,
- Removable drawers with telescopic rails for easy cleaning,
- Removable 12 lt waste bin,
- Bowl can be inserted under table when not used, enabling a smaller volume for trolley,
- Four swivel casters, two of them with brakes,
- Custom production for specific sizes.





Surgical Tool Wash Sink Model ER-1125 / ER-1144

- Designed for sterilization centers, Washing/Disinfection rooms and for all types of washing units,
- Made of AISI 304 quality 18/8 CrNi stainless steel,
- Available production with single, double, triple or more sinks with respect to the size of sterilization center,
- Suspension legs made of first class stainless steel with adjustable height and balance,
- Custom production for specific sizes.

Ergonomic Serum Hanger



Work Table with Cupboard Model ER- 1150 / ER- 1154

- Designed for surgical operation and medical intervention rooms,
- Made of AISI 304 quality 18/8 CrNi stainless steel,
- Four removable drawers with telescopic rails for easy cleaning,Cupboard section with easy to use sliding door mechanism and with a middle shelf.
- Four Suspension legs made of first class stainless steel with adjustable height and balance,
- Custom production for specific sizes.

Packing Table

Model ER- 1175 / ER-1182

- Designed to use in sterilization units, packing departments and in hygienic environment,
- Made of AISI 304 quality 18/8 CrNi stainless steel,
- Four swivel casters, two of them with brakes,
- Rubber bumpers on the corners to prevent damage on wall, door and other surfaces in case of a collision,
- Optional manufacturing from plastic covered wood material for upper and lower trays,
- Optional drawer and power socket,
- Custom production for specific sizes.



Light Table

Model ER1200 / ER1205

- Designed to use in controlling and packing textile materials,
- Made of AISI 304 quality 18/8 CrNi stainless steel,
- Removable, transparent plexiglass plate on upper tray,
- Illumination of upper tray with lamps under it, controlled by a switch,
- Suspension legs with adjustable height and balance, optional production with swivel casters,
- Optional manufacturing from plastic covered wood material for upper and lower trays,
- Custom production for specific sizes.

Medicine & Instrument Trolley

Model ER1225 / ER1128

- Designed to use in surgical operation rooms and all hygienic rooms,
- Made of AISI 304 quality 18/8 CrNi stainless steel,
- Fences surrounding the top except the operator side to prevent the material falling down,
- Six drawers and one cupboard section,
- Removable drawers with telescopic rails for easy cleaning,
- Handles on cupboard and drawers, made of first class stainless material,
- Four swivel casters, two of them with brake,
- Custom production for specific sizes.





Hygienic Material Cupboard Model ER1250 / ER1253

- Designed to use in surgical operation and medical intervention rooms,
- Made of AISI 304 quality 18/8 CrNi stainless steel,
- Three cells to store galosh, bonnet and mask separately.
Optional production of 6-cell store by adding another shelf on top,
- Rubber covering of sharp sides of cells to prevent hand cuts,
- Waste section with an easy opening door at the lower part,
- Handle made of first class stainless material,
- Four swivel casters, two of them with brakes,
- Custom design and production for specific types

Tool & Package Trolley with Drawer Model ER1275 / ER1278

- Designed to use in surgical operation rooms and all hygienic rooms,
- Made of AISI 304 quality 18/8 CrNi stainless steel,
- Fences surrounding the top except the operator side to prevent the material falling down,
- One removable drawer with telescopic rails for easy cleaning,
- Four swivel casters, two of them with brake,
- Custom production for specific sizes.



Tool & Package Trolley / Model ER1300 / ER1303

- Designed to use in surgical operation rooms and all hygienic rooms,
- Made of AISI 304 quality 18/8 CrNi stainless steel,
- Fences surrounding the top except the operator side to prevent the material falling down,
- Four swivel casters, two of them with brake,
- Custom production for specific sizes.

Tool Table

Model ER11325/ ER1328

- Designed for surgical operation rooms and all hygienic rooms,
- Made of AISI 304 quality 18/8 CrNi stainless steel,
- Two-tray structure,
- Four swivel casters, two of them with brake,
- Custom production for specific sizes.



Container Carriage Trolley

Model ER1375

- Designed to carry containers and wire baskets at sterilization units,
- Made of AISI 304 quality 8/8 CrNi stainless steel,
- Can carry fifteen of containers (3+6+6)
- Custom production for specific sizes.



Closed Carriage Trolley

Model ER1450

- Designed to carry containers and material between contaminated and clean rooms in sterilization centers,
- Made of AISI 304 quality 8/8 CrNi stainless steel,
- Secured transfer of sterilized materials to store room,
- Four swivel casters, two of them with brake,
- Custom production for specific sizes,
- Optional number of shelves.



Shelf System Model ER1550

- Designed for surgical operation rooms, sterilized material storage and other units,
- Made of AISI 304 quality 18/8 CrNi stainless steel,
- Portable shelves with three, four or five-shelf configuration,

Shelf System Model ER1600

- Made of AISI 304 quality 18/8 CrNi stainless steel,
- Portable shelves with three, four or five-shelf configuration,
- Four swivel casters, two of them with brakes in ER1600 model.



Waste Bucket Model ER1350/ ER1351

- Designed for surgical operation and medical intervention rooms,
- Made of AISI 304 quality 8/8 CrNi stainless steel,
- Custom production for specific sizes.

Containers

Model ER1400 / ER1403

- Made of specific aluminium material,
- Colored lids to prevent to get mixed up or lost of surgical instruments,
- Tiny openings on lid enabling the sterilization of the material inside easily,
- Handles for easy carrying,
- Labeling for easy classification and identification of the material inside.



Wire Baskets – Strainers

Model ER1425

- Made of specific stainless material,
- Durable and rigid structure,
- Prevents to get mixed up and lost of surgical instruments during sterilization,
- With a honeycomb structure, it provides easier pre-cleaning with water or other liquids during pre-sterilization,
- Handles to carry easily.

Waste Bucket

Model ER1350/ ER1351

- Designed for surgical operation and medical intervention rooms,
- Made of AISI 304 quality 8/8 CrNi stainless steel,
- Custom production for specific sizes.





Containers /

Model ER1400 / ER1403

- Made of specific aluminium material,
- Colored lids to prevent to get mixed up or lost of surgical instruments,
- Tiny openings on lid enabling the sterilization of the material inside easily,
- Handles for easy carrying,
- Labeling for easy classification and identification of the material inside.

Wire Baskets – Strainers

Model ER1425

- Made of specific stainless material,
- Durable and rigid structure,
- Prevents to get mixed up and lost of surgical instruments during sterilization,
- With a honeycomb structure, it provides easier pre-cleaning with water or other liquids during pre-sterilization,
- Handles to carry easily.



Hospitals Structure,
Industrial and Municipal
Services may have been
contaminated in the field
of processing them and
sterilization of
medical waste.



09 - MEDICAL WASTE MANAGEMENT SOLUTIONS

 erylğit



Ankara - Factory
İvogsan Özanadolu San. Sit. 1453. St. No.3
TR 06370 Ostim / Yenimahalle / Ankara / Türkiye

Tel: +90 312 395 57 95 (pbx) - Fax: +90 312 395 57 96

www.twitter.com/eryigitas

www.eryigit.com.tr - info@eryigit.com.tr

ERY-3 / Date of Issue : 14/03/2016, Ankara Rev.3